

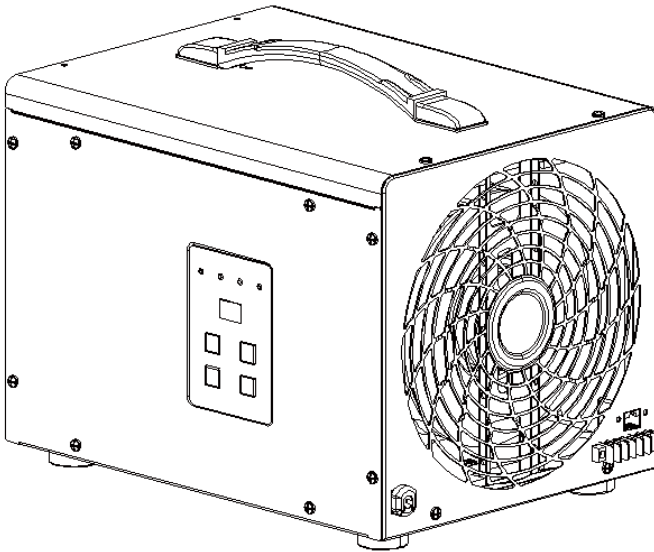

ABESTORM

Guardian SN35P

Installation & Operations Manual



Abestorm Solutions INC.

Add: 8605 SANTAMONICABLVD#79525
WEST HOLLYWOOD, California, 90069 USA

E-mail: sales@abestorm.com

Note: as we keep upgrading our product, we reserve the right to modify the product without notice in advance

Table of Contents

Warranty Registration	2
Safety Notes	2
Identification	3
Electrical Supply	3
Principle of Operation	3
Installation	4
Key Functions	4
Indicator lights	6
Remote Control	6
Diagram	8
Maintenance	8
Dehumidifier Storage	8
Troubleshooting	9
Maintenance and application of water pumps.....	10
Spare Parts	13
Warranty Information.....	14
Motherboard Wiring Diagram.....	15
Warranty Card	16

Warranty Registration

Congratulations on your purchase of a Guardian SN35P dehumidifier. Your new dehumidifier comes with an extensive warranty program. To register, simply complete and return the warranty form provided in the dehumidifier box.

Be sure to include your dehumidifier's serial number, as you will need it to register.

Safety Notes

- The Guardian SN35P dehumidifier must always use a grounded electrical connection (as required for all appliances). If a non-grounded wire is used, all liability goes to the buyer and the warranty is void.
- Your new dehumidifier comes with an extensive warranty program. To register, simply complete and return the warranty form provided in the dehumidifier box. Be sure to include your dehumidifier's serial number as you will need it for registration.
- The Guardian SN35P dehumidifier should be maintained and repaired by a qualified technician.
- The Guardian SN35P dehumidifier is intended for operation when the unit is standing and horizontal only. Operating the unit in any other direction may allow water to flood the electrical components.
- Always unplug the dehumidifier before moving.
- If water threatens to flood the dehumidifier, turn off and unplug the dehumidifier.
- To ensure proper operation, the dehumidifier's air inlet and air outlet should be at least 6 feet away from a wall or any obstruction.
- Do not insert fingers or any objects into the inlet or outlet holes.
- The dehumidifier should be turned OFF and unplugged when performing maintenance or repaired. Before repairing the dehumidifier, contact our customer support team. Some procedure must be performed by a qualified technician.
- Do not use water to clean the exterior of the machine. To clean the unit, unplug the power and wipe the exterior with a damp cloth.
- Do not stand on the machine or use it as a device for hanging clothes.

Identification

Please write down the model number, serial number and date of purchase of the dehumidifier for future reference. If you need to ask for help in the future. This is very useful. The data label on the side of the unit has the key features of the particular machine.

Model Number: Guardian SN35P

Serial Number: _____ **Date of Purchase:** _____

For additional questions about your dehumidifier, email sales@abestorm.com.

Electrical Supply

Power supply: 115V, 60Hz AC, single phase

Outlet requirements: 3 holes, GFCI

Circuit protector: 15 amps

Warning: 240 volts AC power may cause serious injury due to electric shock.

To reduce the risk of injury:

- 1 Disconnect the power supply before servicing.
- 2 Only plug the device into a grounded circuit.
- 3 Do not use extension cords.
- 4 Do not use plug adapters.

Principle of Operation

The Guardian SN35P dehumidifier reads the relative humidity in the room. When the detected relative humidity exceeds the humidity setpoint, the dehumidifier will automatically turn on. The air passes through the evaporator coil, which is cooler than the dew point of the air. This means that moisture condenses out of the air. The air is then reheated through the condenser coil and distributed back into the room.

Installation

The area to be controlled should be sealed with a vapor barrier. If the equipment is installed in a confined space, all vents should be sealed.

WARNING: Do not install the dehumidifier in a corrosive environment. Some liquid vapor barriers dry by "solvent evaporation". Always make sure the barrier is completely dry.

Step 1: Place the dehumidifier on a level surface.

Do not place the dehumidifier directly on the vapor barrier. It is suggested to place the dehumidifier on a level block or paver.

Wait for at least 12 hours before turning on the dehumidifier after delivery.

Step 2: Set up the drain line.

Remove the nut from the drain nozzle before connecting the drain hose when using the dehumidifier's pump drain system.

To use the gravity drain system, locate the other drain nozzle on the side of the unit. Remove the drain plug and connect the drain hose (with a larger inner diameter) onto the other drain nozzle.

Step 3: Plug the unit into a 15-amp ground circuit.



Key Functions

1. The "ON /OFF" Button

- Press this button to turn ON/OFF the dehumidifier.
- When the dehumidifier is turned off, there would be a 120 seconds delay on the fan. Do not unplug the unit until the fan is off.

2. "SET" Button

- This button is used to change the humidity setpoint from 25% to 80%. The dehumidifier may also be set at "CO" or Continuous Operation mode to run the dehumidifier continuously. The setpoint has 5% increments of each press.

3. "Drain" Button

- Hold this button down for at least 3 seconds to switch the drain system to use. Either pump drain system or gravity drain system.

Water Pump Drainage Mode:

- If the "Pump" light is turned ON, it indicates that the pump drain system is in use. (The gravity drain nozzle must be blocked to cover the drain hole)
- The "Drain" button can be pressed once to force the water pump to remove the collected moisture from the water tray for 14 seconds. During pump operation, this button is not valid.
- If the water pump float switch detected a high level of water in the tray, the pump will automatically run and drain the collected moisture for 14 seconds. If a high level of water is still detected, after the pump runs for 14 seconds, the screen will display an "E4" error code.

Gravity Drainage Mode:

- If the "Pump" light is turned OFF, it indicates that the gravity drain system is in use. The Water Tray Plug should be removed from the dehumidifier to properly use this drain system. This allows the dehumidifier to continuously drain the moisture collected.
- If a high level of water is detected by the float switch for 14 seconds, the screen will display an "E4" error code and the dehumidifier will STOP from running to avoid a water leak.

Note: When moving the machine from one location to another, wait at least 10 minutes after turning off. This will allow the moisture in the coil to drip down in the water tray and you may tilt the dehumidifier in the direction of the drain hole to remove the collected moisture or water, completely.

4. "GPP" button

- This button is used to change the humidity reading from RH% to GPP (Grains per pound). GPP is the unit used to measure the weight of moisture in the air. The number of grains per pound of dry air expresses the specific humidity of the air. The GPP setpoint can be set at 25 to 200.
- Relative humidity (RH) refers to the moisture content of the atmosphere, expressed as a percentage of the amount of moisture that can be retained by the atmosphere at a given temperature and pressure with condensation.

"SET +Drain" key

- The SET+Drain key combination is used to display the temperature of the temperature sensor by pressing and holding for 3 seconds.

"SET +GPP" key

- "SET + GPP" key combination press for 3 seconds to display the temperature of the coil in Celsius.

Indicator lights

1. Humidity display screen

- The display screen has two functions

1 By default, the screen displays the Relative humidity level in the space.

2 While setting the humidity setpoint, the screen displays the current setpoint. After 2-3 seconds, the display will return to the default screen to display the Relative humidity level in the space.

2. Operation Indicator Power

- When the power light is solid green, it indicates that the dehumidifier is turned on. If this light is flashing, it means that the dehumidifier has reached the desired humidity level in the space.

3. Continuous mode light Continue

- When this light is on green, it indicates that the dehumidifier is set to continuous operation mode. In continuous mode of operation, this light is always on, other states, this light is off.

4. Water Pump Drainage Pump

- Water pump mode, this light is on; gravity drainage mode, this light is off. The factory default mode of the device is gravity drainage mode

5. GPP mode indicator GPP

- When the compressor is in GPP mode, this light is on; in regular mode, this light is off

Remote Control Instructions

The Abestorm 35P dehumidifier can be controlled using the (optional) wired remote accessory. It is connected via a 25 inch CAT5 Cable. The remote control contains an integrated sensor which also detects the temperature and humidity level of the room where the remote controller is placed in

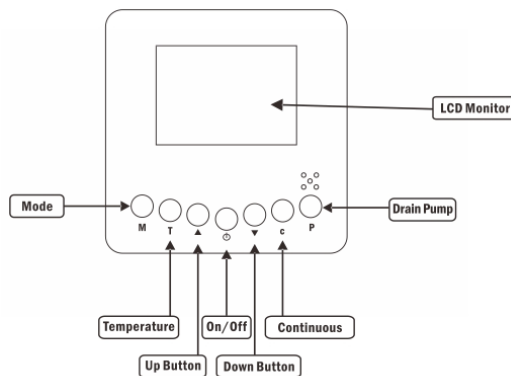

1. On/Off Power (Button)

- Press the on/off button and the machine will start running . Press the button again to turn off the machine.

2. Up Button ▲ / Down Button ▼

- Use the up and down arrow buttons to adjust the humidity level.

3. Mode M

- Use the Mode button to switch between dehumidification and a ducted application.
- The ☉ symbol on the display board indicates the sensor on the remote control is being utilized.
- The ♣ symbol on the display board indicates the sensor on the dehumidifier is being utilized.

4. Temperature T

- Press the temperature button to display the current temperature on the screen. The T button toggles the temperature scale setting back and forth °C / F°.

5. Continuous C

- Pressing this button will switch the unit to continuous mode. cont will appear on the display to indicate continuous mode.

6. Drain Pump P

- Press this button to drain or pump the collected moisture or water out of the dehumidifier.

NOTE: The above symbol will only appear when the dehumidifier is powered on.

(Pressing the P button screen displays Draining indicating that it is draining anddisappears when the drainage is complete).

Dehumidifier Diagram

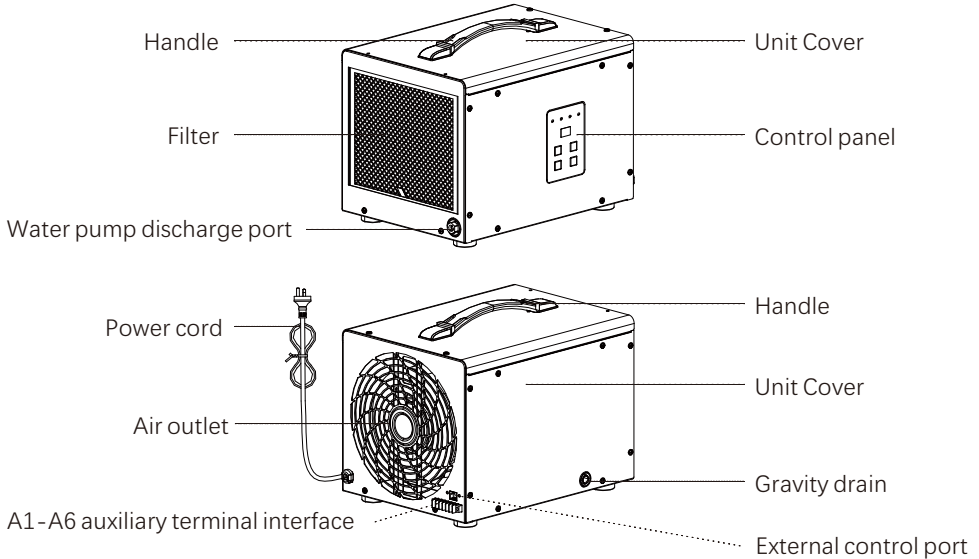

Maintenance

WARNING: Always unplug the power before performing any maintenance.

Cleaning the body

Use a soft damp cloth to clean the exterior of the unit. Do not use any soap or solvent.

Coil Maintenance

Once a year, clean coils with an approved coil cleaner. Coil cleaner should be a self-cleaning, foaming cleaner such as WEB® Coil Cleaner.

Dehumidifier Storage

If the unit will be stored for an extended period of time, complete the following steps:

1. Turn the unit off and allow it to dry.
2. Pack and secure the power cord.
3. Cover the filter.
4. Store in a clean, dry place.

Troubleshooting

Symptom	Cause	Solution
Machine Won't Run	Power Supply	Verify that the outlet has power and that the plug is properly installed in the outlet
	Room Temperature Exceeds 105°F (HI Displayed) or is Below 33°F	Unit is outside of operating temperature range. Modify room conditions so that the temperature is between 33°F and 105°F the system will begin to operate. (Machine set humidity degree must be less than ambient humidity for machine to operate)
Low Air Flow	Air Filter is Clogged	Clean the filter according to the instructions listed in the manual.
	Air Inlet or Outlet is Clogged.	Clear blockage on inlet or outlet.
Loud Noise	Machine is Not Level	Move it to a flat surface.
	Filter is Clogged	Clean the filter according to the instructions listed in the manual.
Trouble code E: 1	E1 = Humidity sensor Issues	Check the wire connections at both ends. If there are no visible problems, the sensor may be faulty.
Trouble code E: 4	Water Pump Failure	Confirm whether the pump is malfunctioning, if so, unplug it for two minutes and restart it. (1. confirm whether the floats switch is effective 2. whether the motherboard chip is damaged)
Trouble code: HI or LO	Room Temperature Exceeds 105°F (HI Displayed) or Below 33°F (LO Displayed)	The machine unit is outside the operating temperature range. Modify room conditions so that a temperature between 33°F and 105°F will begin operation. If the room conditions are within the temperature range, replace the sensor.
Trouble code E: 5	Refrigerant Leak	Contact Your Installer for Assistance.

Pump Alarm Trouble Code E4

1. Reset the unit by disconnecting the power cord, then reconnecting it.
NOTE: The unit will not work until the error code is cleared.
2. Manually check if the pump is operational by pressing the drain button. Check that the pump is properly powered on and off. Also, check to see if any water is draining from the unit.
3. If the system has not been cleaned recently, check the discharge line for obstructions, then check the balance of the pump system (see "Maintenance" on page 8 for details).

If maintenance alone is not enough, the hoses and/or pumps can be replaced

Maintenance and application of water pumps

Normal use of the water pump

1. To verify if the drain button is functional.

When the power is on, press the drain button. If the collected moisture is properly drained through the water tray nozzle, this indicates that the condensate pump is not defective.

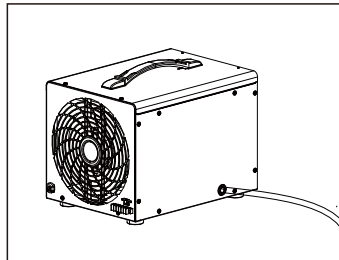

Gravity Drainage



Drain

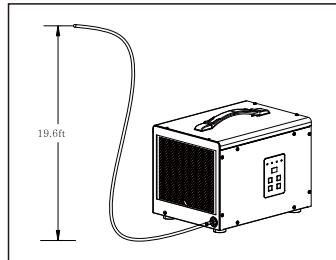

Water Pump Drainage

2. To verify if the automatic drain system is functional.

When the dehumidifier automatically activates the pump after a certain amount of moisture is collected, this indicates that the float switch is working properly.

3. Pump Error.

In the event of a pump failure, the screen will display a "E4" Error code to stop the dehumidifier from running to prevent water leak."

Use of gravity drainage pipe (gravity drainage or pump drainage can be selected according to the working environment)

When the gravity drain system is in use, elevate the unit from the ground. This can be done by hanging the dehumidifier on the floor joist or using a level object to place the dehumidifier on. Failure to elevate the unit higher than the drain pipe will result to a water leak.

Gravity Drainage

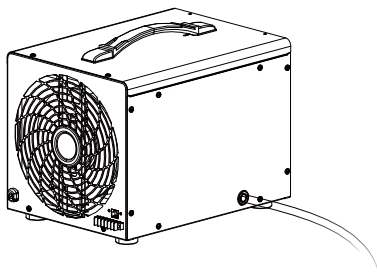

Water pump fault judgment and maintenance methods

Judgment of the problem when the error code "E4" appears.

1. The drainage hose is blocked by foreign objects or bent and deformed
2. The drainage height exceeds the standard.
3. Water level switch failure.
4. The water pump is malfunctioning or its service life has expired.
5. The internal water pump hose is blocked or bent or deformed by foreign objects.

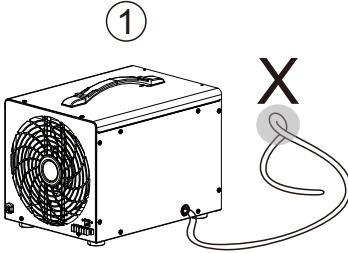

Gravity drainage

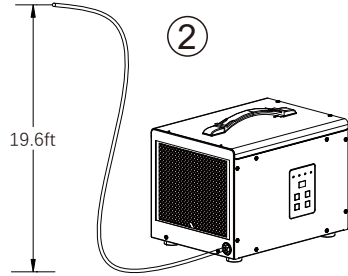

Water pump drainage

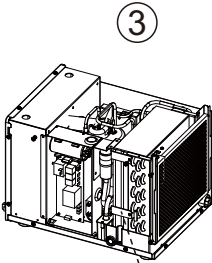

Water level controller switch

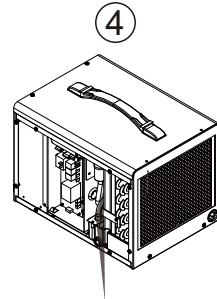

Internal Hose

Water pump repair method

1. Use a Phillips screwdriver to unscrew the screws on the water pump panel, and you can see the fixed status of the water pump.
2. Use a Phillips screwdriver to unscrew the screw of the pump fixing bracket.
3. Pull out the hose fixed in the water reservoir and take out the water pump for replacement.
4. Follow the above steps to install the new water pump to the original position.

①

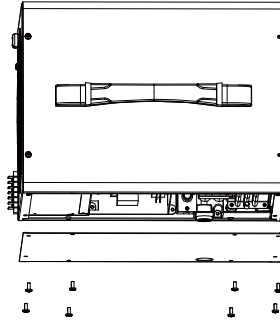

②

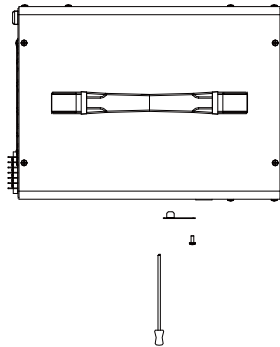

③

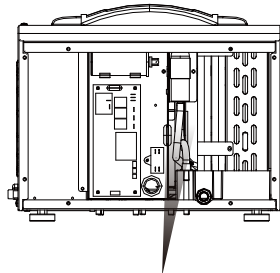

Disconnect the hose

Guardian SN35P Spare Parts

Guardian SN35P Models-Parts	
Part#	Description
S-100	Remote Control Kit (cable + remote control)
S-108	Main Control Board
S-109	Display Board
S-110	Temperature and Humidity Sensor
S-601	Blower Motor
S-602	Air Duct Set
S-603	Fan Capacitor
S-604	Compressor
S-605	Compressor Capacitor
S-606	Coil Assemblies
S-607	Humidity Sensor Wiring
S-608	Display Board Wiring
S-609	A1 - A6 Plug-in Cable Set
S-610	Adjustable Foot Pad
S-611	Water Pump Assembly
Guardian SN35P Filter	
S-612	MERV-1 Filter

Limited Warranty

This limited warranty period begins on the date of purchase. Abestorm warrants to the original purchaser that during the following limited warranty period that the Abestorm product is free from manufacturing defects in material or workmanship.

six (6) months for parts and labor.

This includes the cost of shipment of replacement parts or equipment.

One (1) year for parts and labor.

This does not include the cost of shipping the defective product back for repair or replacement.

Three (3) years of parts and labor on the refrigeration system only

(compressor, condenser and evaporator). Transportation costs, not included.

Five (5) year parts only on the refrigeration system

(compressor, condenser and evaporator). Shipping costs, not included.

This limited warranty applies only to units purchased from the manufacturer or an authorized Abestorm dealer and purchased in accordance with the instructions contained in this User's Guide or with the product for operation, installation and maintenance. Abestorm will not provide home service during or after the warranty period. You may be responsible for shipping costs to bring the product to the manufacturer for service.

To obtain warranty service, the buyer must contact Abestorm at **(888) 276-9833** or sales@abestorm.com. Warranty service requires proof of purchase or order number. During the applicable warranty period, a product will be repaired or replaced at the sole option of Abestorm.

IMPORTANT NOTICE: Keep the item's packaging in case warranty service is required.

Limited Warranty Exclusions

This limited warranty covers manufacturing defects in materials or workmanship encountered in the normal domestic, commercial or non-commercial use of this product. Defects, excluding the following.

- Damage caused by this product during unintended use.
- Damage caused by unauthorized modification or alteration of the product.
- Cosmetic damage, including scratches, dents, chips, and other damage to the finish of the product.
- Damage caused by abuse, misuse, pests, accidents, fire, floods, or other acts of nature.
- Damage caused by abuse, misuse, pests, accidents, fire, floods, or other acts of nature.
- Damage caused by incorrect line currents, voltages, fluctuations and surges.
- Damage caused by failure to properly maintain the product.

The Use of this product in SPA or a room with an outdoor pool invalidate or void limited warranty.

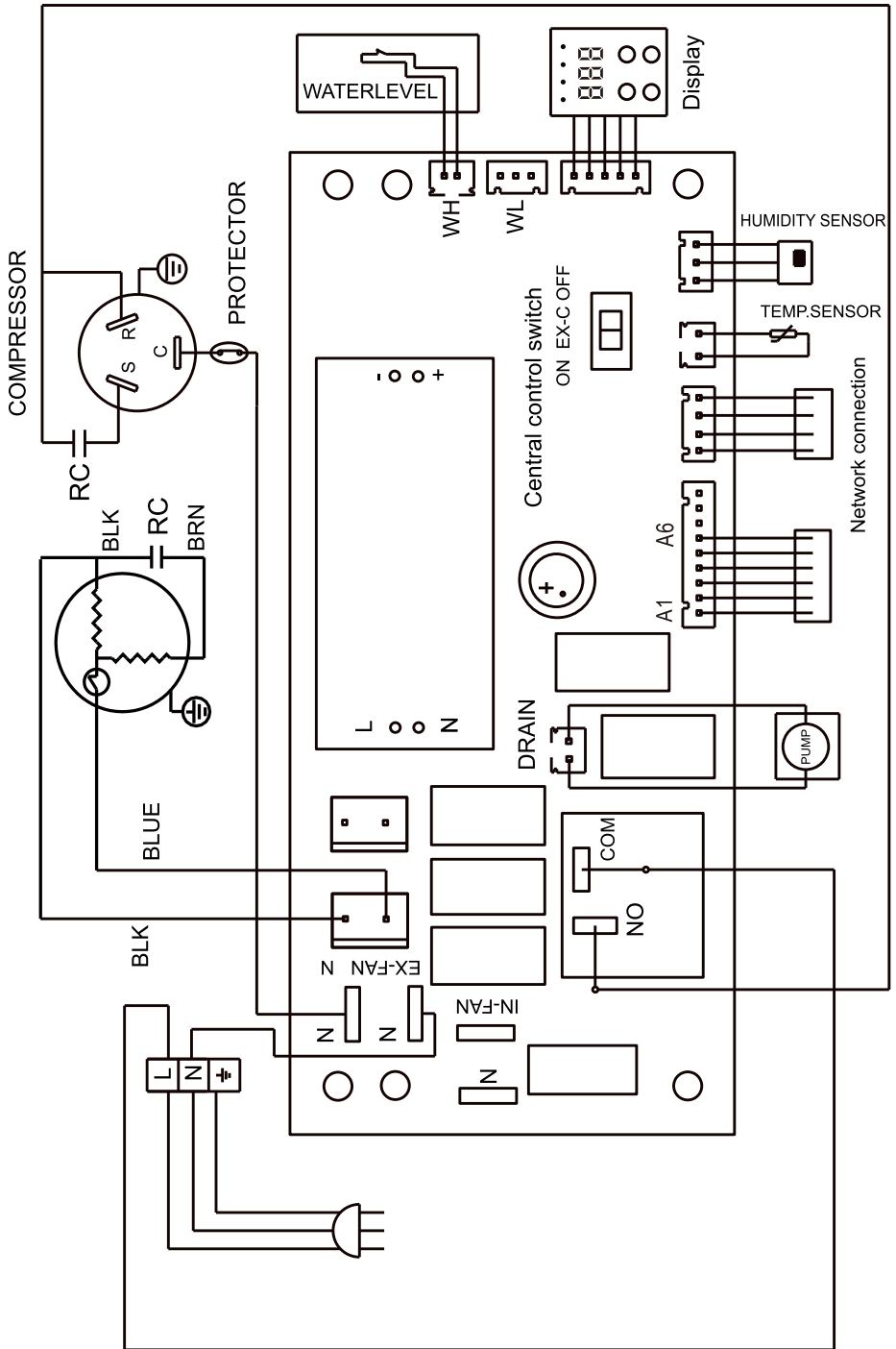



ABESTORM

WARRANTY REGISTRATION CARD

ORDER NUMBER: _____

MODEL: _____

SERIAL #: _____

INSTALLER: _____

REGISTRATION DATE: _____

NAME: _____

ADDRESS: _____

CITY: _____ STATE: _____ ZIP: _____

PHONE #: _____ EMAIL: _____

return to:
Abestorm solutions

- ▶ If you have any questions, please feel free to contact us at (888)276-9833 or visit www.abestorm.com
- ▶ Register your unit for warranty using this link: <https://www.abestorm.com/service-warranty>



